

# CAP COVER / COVER TUBE APPLICATION WORKSHEET

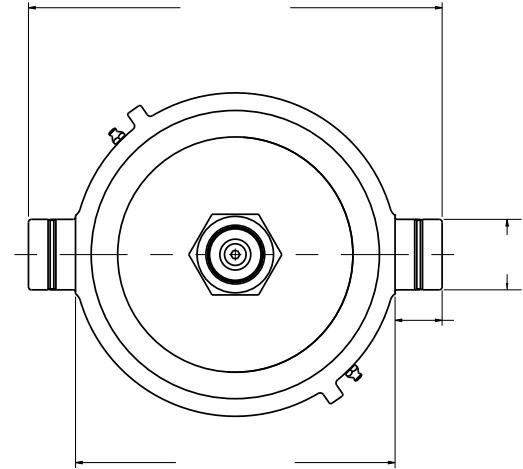
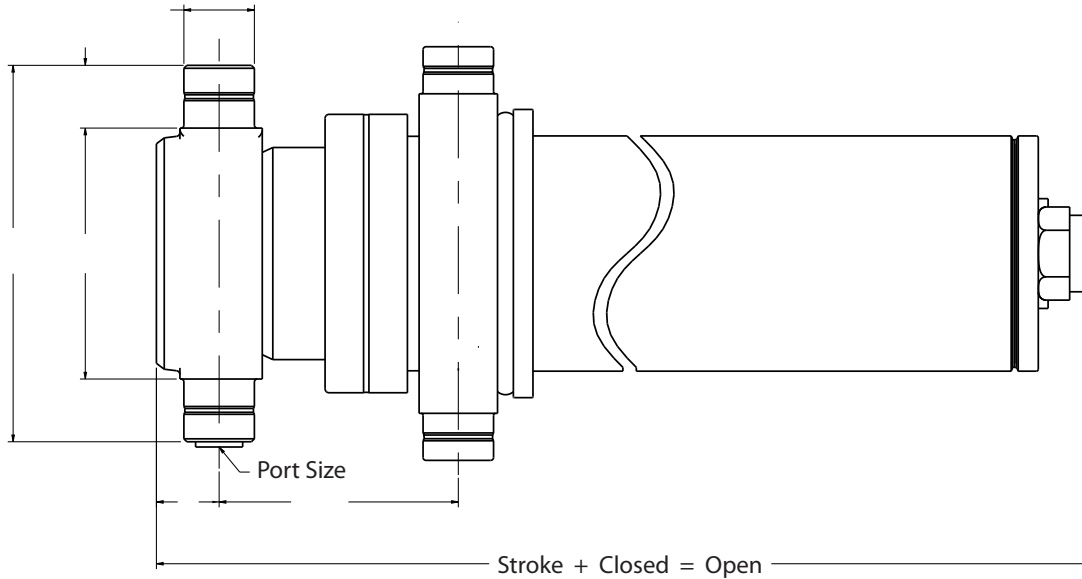

**Fill Out Dimensions Between Arrows**

Add notes if anything is special

---



---

**CUSTOMER**

**CONTACT**

**PHONE**

**FAX**

**EMAIL**

---